

# LIND FORD INDUSTRIES

## MODEL 41005 SERIES CHARGER



**+ Portable + Robust**  
**+ Charges up to 10 x 12 volt Batteries**  
**at a time, at 1 - 10 Amps**

The Model 41005 Battery Charger is designed for Battery Resellers, large Garages and other commercial users. This charger will charge from 1 (ONE) 6 Volt Battery to up to 10 (TEN) 12 Volt Batteries in series.

Fine and coarse controls allow charge rates from 2 amp to 10 amp to be selected.

- + All parts, information and service are available from the manufacturer and distributor
- + Designed for Commercial Use
- + Short circuit and reverse polarity on overload protection

For more information or to order, please visit:

**batterychargers.co.nz**

or call us on 027 289 5611 or email [sales@batterychargers.co.nz](mailto:sales@batterychargers.co.nz)

Distributed in New Zealand by Battery Chargers NZ, 173 Mosston Road, Whanganui 4501

All Lindford chargers  
and testers are proudly  
made in New Zealand



# MODEL 41005 SERIES CHARGER

## CAUTION

High voltages are present on OUTPUT LEADS when power is on. DO NOT switch mains on UNTIL output leads have been connected to batteries.

**DO NOT TOUCH OUTPUT LEADS WITH POWER ON**

## OPERATING INSTRUCTIONS

1. Switch mains ON/OFF switch to "OFF" position.
2. Turn "COARSE and FINE" controls to position 1 (ONE)
3. Arrange batteries (battery) to be charged in correct manner (ie in series) and connect RED lead to POSITIVE (+) Terminal and BLACK lead to NEGATIVE (-) Terminal (see diagram below).
4. Plug mains plus into 220/240 Volt A.C. outlet and turns mains "ON". The light in the switch will light if power is on to unit and mains circuit breaker is on (pushed in)
5. Turn "COARSE" control to first reading on ammeter and adjust "FINE" control to suit

Charger may be used at full output rating (8-10 amps), at all times however, the Charger will self limit on more than 60 cells, (10 batteries) to about 6-8 amps.

6. See Instructions with Charger for further details.

**PACKED WEIGHT: 19.7kg**

**MEASUREMENTS: 255mm W x 340mm D x 305mm H**

**Diagram: Example 3 x 12v Batteries can be different sizes (Amp HR or CCA)**

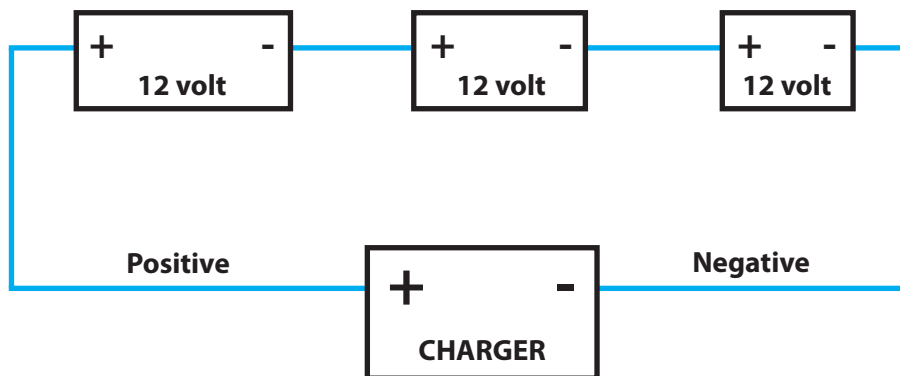

**For the Australian market, this device meets the EESS Electrical Equipment Safety Specifications**